

MODEL

4AXIS

CARTESIAN PALLETISER

Palletising stations for integrating into automatic lines, adaptable to work with any kind of rigid or semi-rigid packaging. They are compatible with a wide range of different containers: boxes, bags, drums, plastic containers, etc. RM machines are the best palletising solution for low and medium production lines as they are low maintenance and space efficient.



FEATURES

- Suitable for a wide range of different products
- Heads customised for the product being handled
- Various installation options so it can be adapted to any available space
- Format changes configured using a touch screen with graphic menu
- Precise handling of products
- Maximum load of 40 kg
- Maximum production of 8 cycles per minute
- CE certification in accordance with 2006/42/CE directive

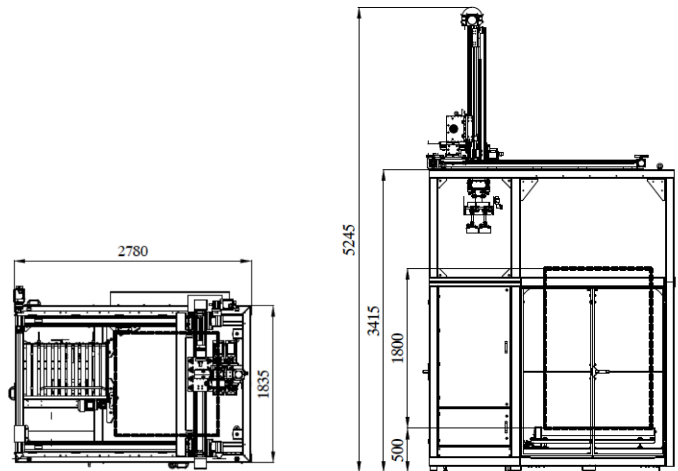

Configuration for 1,800 mm height pallet on 500 mm conveyor. Check sizes for other options.

Maximum load measurements		
Width	Length	Height
1200 mm	1200 mm	2400 mm

Working requirements	
Voltage	230/400v III+T+N
Installed capacity	7.5 kW
Power consumption	6.0 kWh
Pneumatic pressure	6 bar
Air consumption	3 l/cycle